



MR imaging of familial superior oblique hypoplasia

Jae Hyoung Kim and Jeong-Min Hwang

Br J Ophthalmol 2010 94: 346-350 originally published online October 12, 2009

doi: 10.1136/bjo.2009.161398

Updated information and services can be found at:

<http://bjo.bmj.com/content/94/3/346.full.html>

These include:

References

This article cites 15 articles, 2 of which can be accessed free at:

<http://bjo.bmj.com/content/94/3/346.full.html#ref-list-1>

Email alerting service

Receive free email alerts when new articles cite this article. Sign up in the box at the top right corner of the online article.

Topic collections

Articles on similar topics can be found in the following collections

[Editor's choice](#) (565 articles)

Notes

To order reprints of this article go to:

<http://bjo.bmj.com/cgi/reprintform>

To subscribe to *British Journal of Ophthalmology* go to:

<http://bjo.bmj.com/subscriptions>



MR imaging of familial superior oblique hypoplasia

Jae Hyung Kim,¹ Jeong-Min Hwang²

¹Department of Radiology, Seoul National University College of Medicine, Seoul National University Bundang Hospital, Seongnam, Korea ²Department of Ophthalmology, Seoul National University College of Medicine, Seoul National University Bundang Hospital, Seongnam, Korea

Correspondence to

Dr Jeong-Min Hwang, Department of Ophthalmology, Seoul National University College of Medicine, Seoul National University Bundang Hospital, 166 Gumiro, Bundang-gu, Seongnam, 463-707, Korea; hjm@snu.ac.kr

Accepted 18 August 2009
Published Online First
12 October 2009

ABSTRACT

Background Congenital superior oblique palsy is usually associated with a structural abnormality of the superior oblique tendon. There have been many reports of familial congenital superior oblique palsy. However, there has been no MRI documentation of familial superior oblique hypoplasia.

Methods Ophthalmological examination and orbital MRI were performed in three patients in a pedigree with familial superior oblique palsy. They showed typical signs of superior oblique palsy, including superior oblique underaction and overelevation in adduction on the affected side, torticollis in the early part of life, and positive head tilt testing.

Results Moderate to severe superior oblique hypoplasia was identified in all three affected family members.

Conclusion Superior oblique hypoplasia confirmed with MRI was useful for clarifying the aetiology of familial superior oblique palsy.

torticollis in the early part of life, positive head tilt test. Ophthalmological examinations were performed by JMH, and the evaluation of MRI by JHK.

MRI was performed on a 3 T system (Intera Achieva; Philips Healthcare, Best, The Netherlands) to evaluate the extraocular muscles in the orbits. Thin-section orbital T2-weighted imaging was performed in the orthogonal coronal plane with a turbo spin-echo technique to evaluate the extraocular muscles, using the following parameters: repetition time/echo time 3657/120 ms, field of view 150×150 mm, matrix 256×256 and section thickness 2 mm. Additionally, axial T2-weighted imaging was performed with 2 mm section thickness to cover the orbit in one patient, and 4 or 5 mm section thickness to cover the entire brain and orbit in the other two patients.

To determine hypoplasia of the muscles, the right and left extraocular muscles were compared based on a side-by-side visual evaluation for their size and shape along the whole length on the coronal T2-weighted images.

RESULTS

Moderate to severe hypoplasia of the superior oblique at the whole length including the tendon and belly was identified in all three affected family members.

Case 1

An 11-month-old boy presented with a head tilt to the right, which had been noticed at 2–3 months of age. Past medical history was not significant. The patient fixed and followed well with both eyes. He had a small left hyperphoria in the primary position, which increased with head tilt to the left. He also showed overelevation in adduction (figure 2A) and left superior oblique underaction. Coronal and axial T2-weighted images of the orbit showed hypoplasia of the left superior oblique at the whole length including the tendon and belly (figure 2B–E). All other extraocular muscles were symmetrical in size and shape.

Congenital superior oblique palsy is usually associated with a structural abnormality of the superior oblique tendon.^{1–4} There have been many reports of familial congenital superior oblique palsy.^{5–7} However, there has been no MRI documentation of familial superior oblique hypoplasia. We discovered a pedigree with three affected patients, who were 11 months, 7 years, and 27 years of age, respectively. The purpose of this study was to document the familial occurrence of superior oblique hypoplasia for the first time.

PATIENTS AND METHODS

Ophthalmological examination and orbital MRI were performed in three patients (11 months, 7 years and 27 years of age, respectively) with familial superior oblique palsy in a pedigree (figure 1). All of them showed typical signs of superior oblique palsy, including superior oblique underaction and inferior oblique overaction on the affected side,

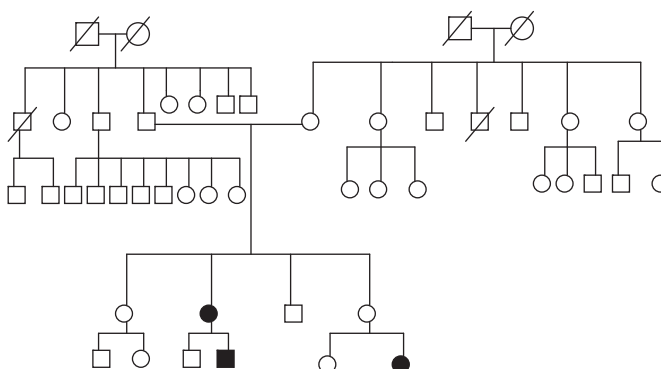

Figure 1 Family pedigree. Affection status is as follows: darkened circles or squares denote an affected individual; clear denotes unaffected. Squares indicate male; circles indicate female; diagonal line indicates deceased.

His mother, a 27-year-old woman, showed orthotropia at distance and near in every gaze and with the head tilt to either side. Her ductions and versions were normal.

Case 2

A 7-year-old boy, a maternal cousin of Case 1, presented with head tilt to the left, first noticed around 1 year of age. Past medical history was not significant. He had right hypertropia of 12 prism dioptres (PD) at distance and right exotropia of 10 PD and hypertropia of 18 PD at near in the primary position without correction. His right hypertropia was 6 PD to the right gaze, and 14 PD to the left gaze, increased to 25 PD with head tilt to the right and decreased to 4 PD with head tilt to the left. The patient exhibited right overelevation in adduction and right superior

oblique underaction (figure 3A). He also showed facial asymmetry with a fuller right side of face. Coronal and axial T2-weighted images of the orbit showed hypoplasia of the right superior oblique at the whole length including the tendon and belly (figure 3B–E). All other extraocular muscles were symmetrical in size and shape.

Case 3

A 27-year-old woman, the mother of Case 2, presented with reduced but persistent head tilt to the left from early childhood, even though she underwent a strabismus surgery at a local clinic 2 years prior. She had right exotropia of 14 PD and right hypertropia of 6 PD in the primary position, right exotropia of 14 PD and right hypertropia of 6 PD in the right gaze, and right

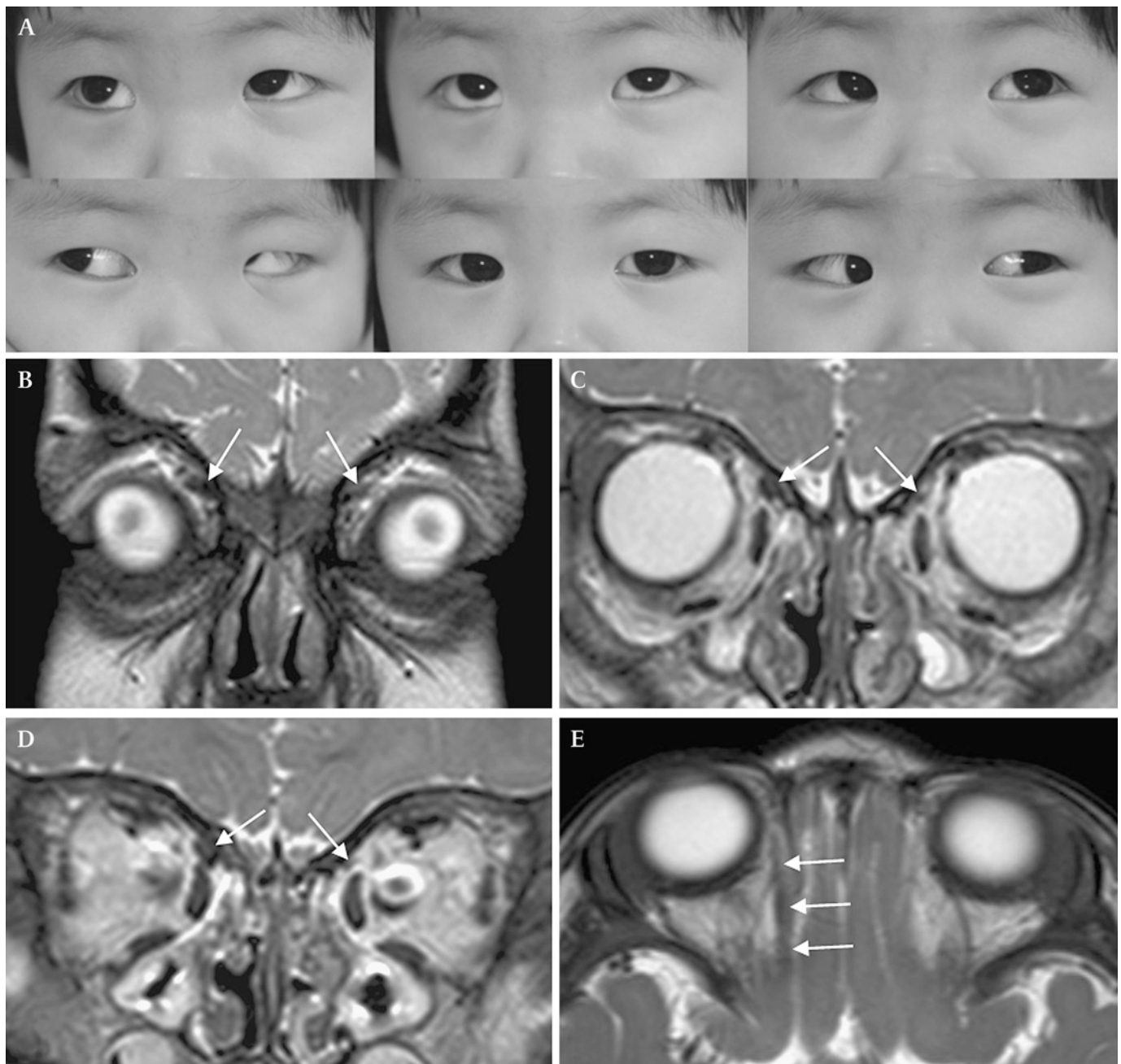

Figure 2 Superior oblique palsy in Case 1. (A) Ocular versions demonstrating inferior oblique overaction in the left eye. (B–E) Two-millimetre-section coronal T2-weighted images showing hypoplasia of the left superior oblique at the tendon (B) and belly (C, D) (arrows). On the 4-mm-section axial T2-weighted image (E), the right superior oblique (arrows) is well visualised, but the left superior oblique is not.

Clinical science

exotropia of 14 PD and right hypertropia of 8 PD in the left gaze. With the head tilt to the right, she showed right exotropia of 16 PD and right hypertropia of 6 PD, and with head tilt to the left, right exotropia of 16 PD and no hypertropia. She showed right superior oblique underaction (figure 4A) and facial

asymmetry with a fuller right side of the face. Coronal and axial T2-weighted images of the orbit showed severe hypoplasia of the right superior oblique (more severe at the belly portion) (figure 4B–E). All other extraocular muscles were symmetrical in size and shape.

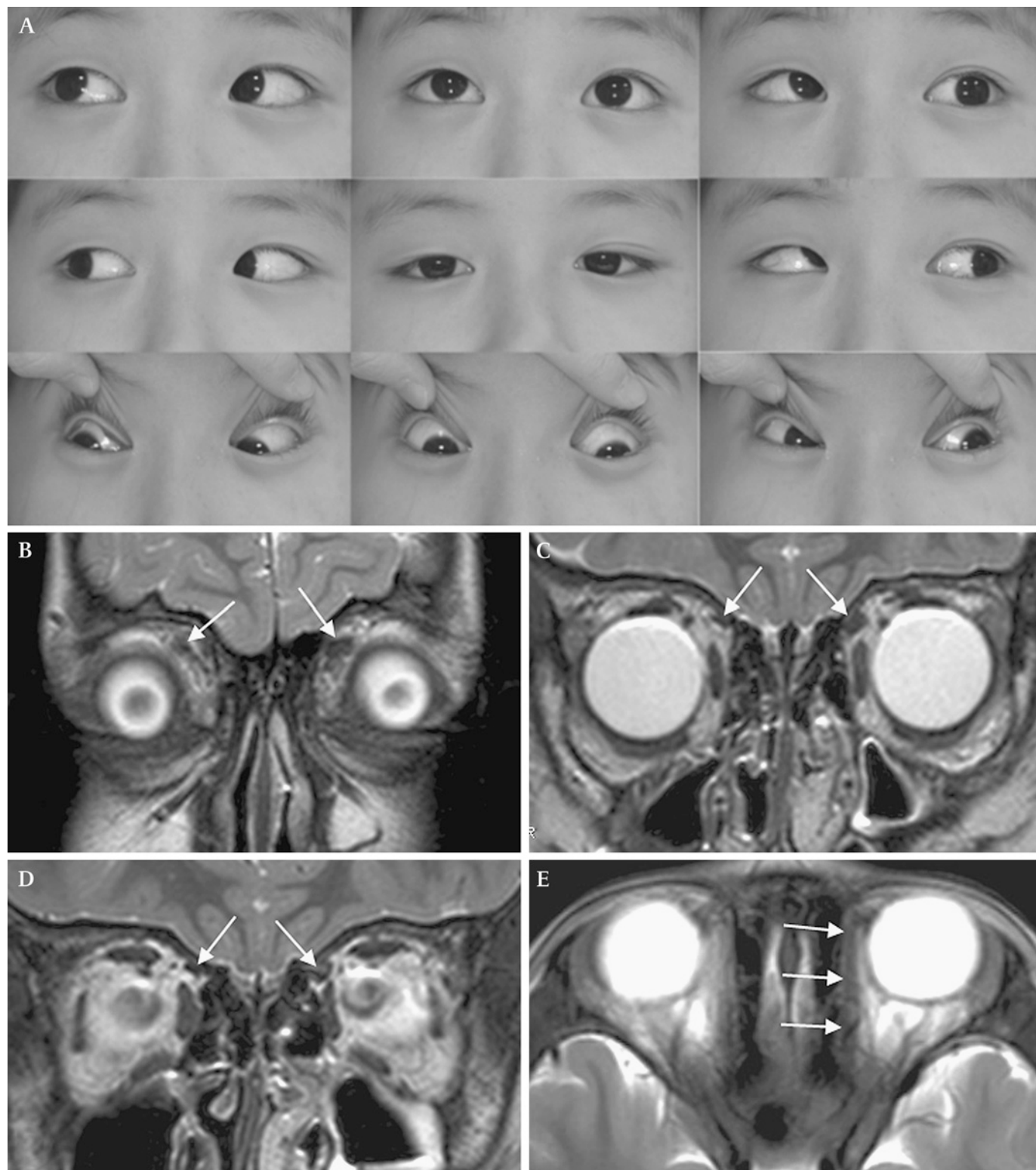

Figure 3 Superior oblique palsy in Case 2. (A) Ocular versions demonstrating inferior oblique overaction and superior oblique underaction in the right eye. (B–E) Two-millimetre-section coronal T2-weighted images showing hypoplasia of the right superior oblique at the tendon (B) and belly (C, D) (arrows). On the 5-mm-section axial T2-weighted image (E), the left superior oblique (arrows) is clearly visualised, but the right superior oblique is not.

DISCUSSION

MR imaging documentation of familial superior oblique hypoplasia has not been previously described. In this study, moderate to severe superior oblique hypoplasia was identified in all three affected family members. They showed typical signs of superior

oblique palsy, including superior oblique underaction and inferior oblique overaction on the affected side, torticollis in the early part of life, and positive head tilt testing. Even though this study included only three patients, superior oblique hypoplasia might at least partly explain the aetiology of previously reported

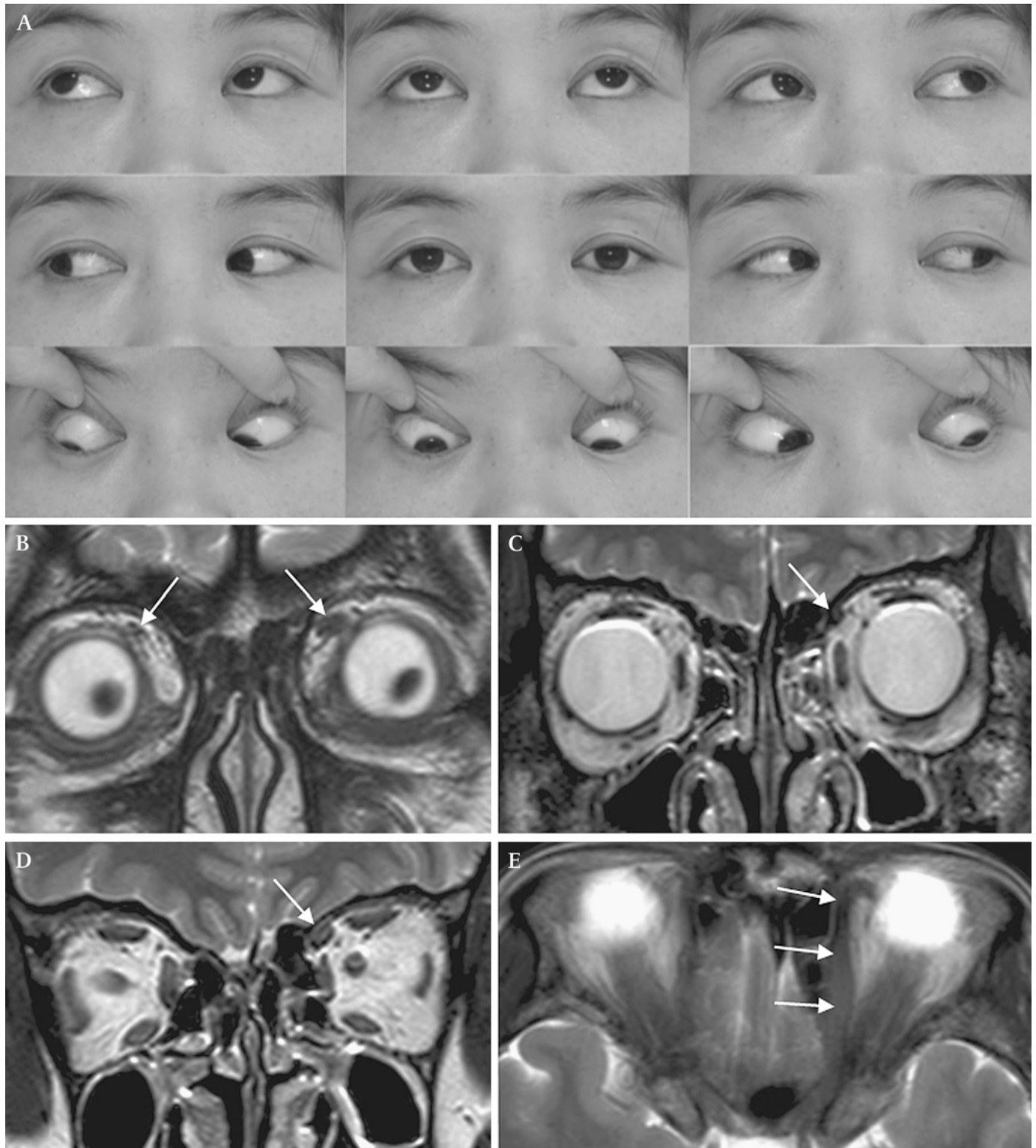

Figure 4 Superior oblique palsy in Case 3. (A) Ocular versions demonstrating superior oblique underaction in the right eye. (B–E) Two-millimetre-section coronal T2-weighted images showing severe hypoplasia of the right superior oblique at the tendon (B) (arrows). The belly portion of the right superior oblique is not found (C, D), suggesting more severe atrophy. On the 2-mm-section axial T2-weighted image (E), the left superior oblique (arrows) is clearly visualised, but the right superior oblique is not.

familial cases of superior oblique palsy. Kono *et al*⁸ suggested that pulley position abnormalities, including temporal displacement of the superior rectus muscle and inferior displacement of the lateral and medial rectus muscle pulleys, may simulate superior oblique palsy. However, none of our patients showed any displacement of the rectus muscles.

Bhola *et al*⁶ suggested autosomal dominant pattern of inheritance of congenital superior oblique palsy. Botelho and Giangiacomo⁷ also suggested autosomal-dominant inheritance of congenital superior oblique palsy and found bilateral absence of the superior oblique tendon at the time of surgery in the 2-year-old boy. Even though Case 1's mother did not show any evidence of superior oblique palsy, this pedigree might also show an autosomal dominant inheritance pattern with incomplete penetrance (figure 1). The chance of pseudo-dominant inheritance in this family caused by a high gene frequency and consanguinity among parents of the affected patients is not slim because the gene frequency of congenital superior oblique palsy is not high, and any marriage within relatives closer than paternal second cousins is prohibited by law in Korea.

Congenital cranial dysinnervation disorders (CCDDs) are the term to describe congenital disorders resulting from aberrant innervation of the ocular and facial musculature. CCDDs are attributable to developmental abnormalities, including the complete absence of the cranial nerves with muscle dysinnervation.^{9–10} Aplasia or hypoplasia of the oculomotor or abducens nerve has been reported in patients with Duane retraction syndrome and congenital fibrosis of the extraocular muscles.^{11–12} There are a few conditions that cause congenital superior oblique underaction such as the hypoplasia of the superior oblique muscle, congenital trochlear nerve palsy and finally inferior oblique overaction. At this moment, whether the hypoplasia of the superior oblique muscle in our patients may be caused by trochlear nerve hypoplasia is not clear. However, the differentiation of hypoplasia of the superior oblique muscle could be possible with MR imaging. In our experience, the trochlear nerve cannot be clearly visualised on thin-section MR images due to its small size, even in normal persons. Therefore, development of much higher-resolution MR imaging to show the morphology of the trochlear nerve is clearly necessary to verify if congenital superior oblique palsy also belongs under the classification of CCDDs.

ARIX or *PHOX2A* is a gene involved in the differentiation of nuclei of the third and fourth nerves.^{13–15} *ARIX* gene polymorphisms were found in the patients with congenital superior oblique muscle palsy and were suggested as one of the risk factors

for the development of congenital superior oblique muscle palsy.¹³ Mutations of *ARIX* gene is also found in families with the type 2 congenital fibrosis of the extraocular muscles.^{14–15} Even though our patients did not show the typical recessive pattern, a further study to investigate the presence of *ARIX* gene polymorphisms might be helpful to understand the pathophysiology of familial congenital superior oblique palsy.

In conclusion, MR imaging proved useful for clarifying the aetiology of familial superior oblique palsy.

Funding This study was supported by a grant from the Korea Health 21 R&D Project, Ministry of Health, Welfare, and Family Affairs, Republic of Korea (A080299).

Competing interests None.

Ethics approval Ethics approval was provided by the Seoul National University Bundang Hospital.

Patient consent Obtained.

Provenance and peer review Not commissioned; externally peer reviewed.

REFERENCES

1. Helveston EM, Krach D, Plager DA, *et al*. A new classification of superior oblique palsy based on congenital variations in the tendon. *Ophthalmology* 1992;**99**:1609–15.
2. Sato M. Magnetic resonance imaging and tendon anomaly associated with congenital superior oblique palsy. *Am J Ophthalmol* 1999;**127**:379–87.
3. Demer JL, Clark RA, Kono R, *et al*. A 12-year, prospective study of extraocular muscle imaging in complex strabismus. *J AAPOS* 2002;**6**:337–47.
4. Chan TK, Demer JL. Clinical features of congenital absence of the superior oblique muscle as demonstrated by orbital imaging. *J AAPOS* 1999;**3**:143–50.
5. Astle WF, Rosenbaum AL. Familial congenital fourth cranial nerve palsy. *Arch Ophthalmol* 1985;**103**:532–5.
6. Bhola RM, Horne GV, Squirrell DM, *et al*. Autosomal dominant congenital superior oblique palsy. *Eye* 2001;**15**:479–84.
7. Botelho PJ, Giangiacomo JG. Autosomal-dominant inheritance of congenital superior oblique palsy. *Ophthalmology* 1996;**103**:1508–11.
8. Kono R, Okanobu H, Ohtsuki H, *et al*. Displacement of the rectus muscle pulleys simulating superior oblique palsy. *Jpn J Ophthalmol* 2008;**52**:36–43.
9. Engle EC, Goumnerov BC, McKeown CA, *et al*. Oculomotor nerve and muscle abnormalities in congenital fibrosis of the extraocular muscles. *Ann Neurol* 1997;**41**:314–25.
10. Traboulsi EI. Congenital abnormalities of cranial nerve development: overview, molecular mechanisms, and further evidence of heterogeneity and complexity of syndromes with congenital limitation of eye movements. *Trans Am Ophthalmol Soc* 2004;**102**:373–89.
11. Kim JH, Hwang JM. Hypoplastic oculomotor nerve and absent abducens nerve in congenital fibrosis syndrome and synergistic divergence with magnetic resonance imaging. *Ophthalmology* 2005;**112**:728–32.
12. Kim JH, Hwang JM. Presence of abducens nerve according to the type of Duane's retraction syndrome. *Ophthalmology* 2005;**112**:109–13.
13. Jiang Y, Matsuo T, Fujiwara H, *et al*. *ARIX* gene polymorphisms in patients with congenital superior oblique muscle palsy. *Br J Ophthalmol* 2004;**88**:263–7.
14. Yazdani A, Chung DC, Abbaszadegan MR, *et al*. A novel *PHOX2A/ARIX* mutation in an Iranian family with congenital fibrosis of extraocular muscles type 2 (CFEOM2). *Am J Ophthalmol* 2003;**136**:861–5.
15. Nakano M, Yamada K, Fain J, *et al*. Homozygous mutations in *ARIX(Phox2a)* result in congenital fibrosis of the extraocular muscles type 2. *Nat Genet* 2001;**29**:315–20.